

[54] **POSTER DISPLAY DEVICE**

[72] Inventor: Robert Sarkisian, 8644 Woodside Park Drive, Oak Park, Mich. 48237

[22] Filed: Sept. 11, 1967

[21] Appl. No.: 670,511

[52] U.S. Cl. .... 40/125 H, 40/145 A, 248/160

[51] Int. Cl. .... G09f 7/00

[58] Field of Search ..... 40/125 H, 145 A, 138; 248/160, 248/373; 297/296

[56] **References Cited**

**UNITED STATES PATENTS**

1,532,865	4/1925	Beck .....	40/145 A UX
1,541,200	6/1925	Thomson .....	40/125 H
2,165,704	7/1939	Hood .....	40/145 A
1,750,118	3/1930	Mueller et al. ....	40/138

**FOREIGN PATENTS OR APPLICATIONS**

339,325	12/1930	Great Britain .....	40/138
---------	---------	---------------------	--------

Primary Examiner—Robert W. Michell  
 Assistant Examiner—Richard Carter  
 Attorney—Whittemore, Hulbert & Belknap

[57] **ABSTRACT**

The poster display device includes a base upon which is mounted a poster frame. The means for mounting the poster frame onto the base comprise a spring structure interconnecting the lower portion of the poster frame to the base. In one embodiment, the spring structure comprises a pair of spaced-apart coil springs which extend between the frame and the base. In another embodiment, the spring structure is an elongated torsion spring mounted transversely of the base. The poster frame has a pair of spaced-apart brackets on the lower edge thereof which engage the torsion springs.

The poster frame, which normally extends vertically upwardly from the base, has a backing member mounted thereon for receiving posters or like advertising or other media. The surface area of the backing member is relatively large. The spring structure upon which the frame is mounted permits the frame and backing member to deflect downwardly upon the application of a force thereto, as for example, the wind when the structure is located out of doors. The frame may deflect in either direction without danger of tipping the base. The stronger the applied force, the more the frame will deflect downwardly thus reducing the component of any force tending to topple the display device.

5 Claims, 6 Drawing Figures

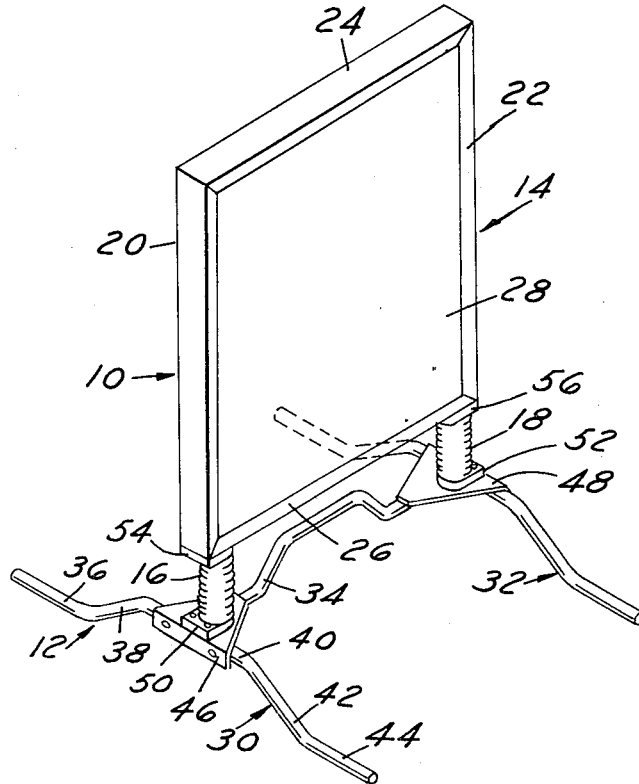

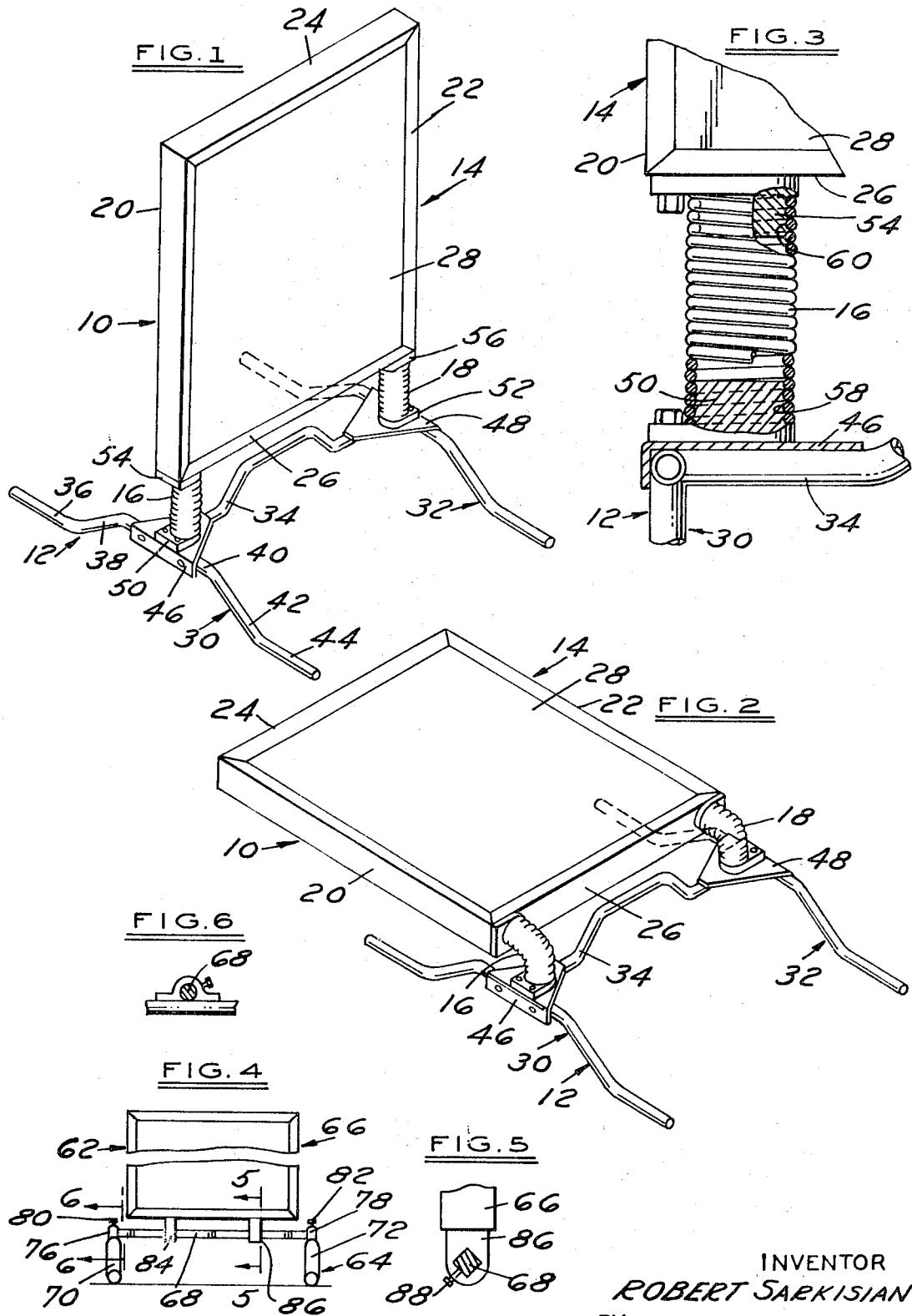

INVENTOR  
**ROBERT SARKISIAN**  
BY  
*Whittemore, Hulbert & Selknap*  
ATTORNEYS

## POSTER DISPLAY DEVICE

## BACKGROUND OF THE INVENTION

Poster display devices of the general type to which the present invention relates have long been in widespread use. The display devices are normally used out of doors to advertise services or products, for example, in front of theatres and gas stations. One of the problems which has been encountered in the past with such poster display devices is that they are frequently tipped over by the wind.

Conventionally, such display devices have comprised a base having an upstanding rectangular hanger structure extending upwardly therefrom. The frame for the advertising poster has been pivotally mounted to the top of the hanger structure. The poster frame has thus been free to swing in a manner similar to a pendulum under the force of a wind. When the wind dies down, the poster frame settles in a central position as a result of gravity. Such devices, in practice, will topple under the force of a strong wind.

The present invention overcomes this problem by providing a poster frame which is mounted to a base by a spring structure which permits the poster frame to be deflected downwardly rather than upwardly whereby the component of the wind force tending to tip the device is diminished as the wind velocity increases.

## SUMMARY OF THE INVENTION

The display device includes a base upon which an upstanding poster frame is mounted by means of a spring structure. The spring structure is connected to the lower portion of the frame at at least a pair of locations. The spring structure normally maintains the frame in an upright position. The spring structure is yieldable to permit downward deflection of the frame in either direction along an axis generally parallel to the frame structure.

## IN THE DRAWING

FIG. 1 is a perspective view of a poster display device in accordance with one embodiment of the present invention.

FIG. 2 is a perspective view of the poster display device in FIG. 1 illustrating the poster frame structure in a deflected position.

FIG. 3 is a view on an enlarged scale of the spring structure which connects the poster frame to the base with portions broken away for the purpose of clarity.

FIG. 4 is a front elevational view of another embodiment of the invention.

FIG. 5 is a sectional view taken substantially along the line 5—5 of FIG. 4 looking in the direction of the arrows.

FIG. 6 is a sectional view taken substantially along the line 6—6 of FIG. 4 looking in the direction of the arrows.

Referring first to the embodiment illustrated in FIGS. 1-3 it will be noted that the poster display device 10 comprises a base structure 12 having a frame structure 14 mounted thereon by means of springs 16, 18.

The frame structure 14 is rectangular in shape and has side members 20, 22, top member 24 and bottom member 26. A rigid backboard or panel 28 is mounted within the frame. The backing member 28 may be fabricated of, for example, a material such as masonite or a metallic sheet material such as aluminum. It will be appreciated that the backing member 28 presents a relatively large surface area which, when subjected to the force of a strong wind, would normally tend to tip the entire device over.

The backing member 28 is adapted to have mounted thereon an advertising poster or the like. Such a poster may be mounted on either or both sides of the backing member. The means for mounting the poster may be an adhesive or like means conventionally used for mounting of posters. One preferred poster holding mechanism is illustrated by my Pat. No. 3,310,901, issued Mar. 28, 1967. In that patent, the frame members are constructed in two parts with the inner portions

being hingedly fastened to the outer portions to permit opening thereof for the reception of a poster. Spring means are provided to bias the inner portions into contact with the backing member so that when the inner portions are closed, they will remain in position and clampingly engage the poster.

The base structure 12 comprises a pair of elongated spaced-apart generally parallel tubular members 30, 32 which are interconnected by a tubular crossmember 34 which extends therebetween.

Referring representatively to the tubular member 30, each tubular member comprises a first horizontally disposed portion 36 which serves as one ground-engaging foot, a second upwardly inclined portion 38, a third horizontally extending portion 40, a fourth downwardly inclined portion 42 and a fifth horizontally directed portion 44 which serves as a second ground-engaging foot. It should be noted that each of the tubular members 30, 32 extends at substantially right angles to the plane of the backing member 28. Thus, any force directed against the backing member will tend to tip the display device about one pair of the spaced-apart feet of the tubular members 30, 32.

A V-shaped mounting plate 46, 48 is secured to the base at each juncture of the crossmember 34. A spring mounting member 50, 52 is secured on each plate 46, 48. A similar spring-mounting member 54, 56 is secured to the undersurface of the bottom frame member 26 adjacent each end thereof. As will be noted in FIG. 3, the spring-mounting members are oppositely disposed. Each of these members has an externally threaded cylindrical portion 58, 60 extending therefrom. The springs 16, 18 which are coil springs, are threaded onto the threaded portions 58, 60 to thereby secure the frame structure 14 to the base structure 12.

Operation of the poster display device may now be understood. Referring first to FIG. 1, it will be noted that the frame structure 14 normally is biased to an upright position by the springs 16, 18. Upon the application of a force against the backing member 28, the frame structure will deflect downwardly as shown in FIG. 2. The greater the force applied, the further the deflection. FIG. 2 illustrates an almost completely deflected frame. In the position illustrated in FIG. 2, the effective force against the display device tending to tip the device is negligible. It will be appreciated that as the frame structure is deflected downwardly, the effective wind force is reduced much in the manner of a sail on a boat coming into the wind.

Several features of the invention may now be understood. The features are as follows:

## 1. Leverage

The bottom of the frame structure 14 is mounted closely adjacent the base structure 12. The mounting plates 46, 48, to which the springs are attached are in turn positioned a short distance from the ground (the vertical distance between the feet of the base and the central horizontal portion 40). There is, therefore, only a short lever action between the point of attachment of the frame structure and the ground. Thus, the force tending to tip the structure is minimized.

## 2. Display Base

The tubular members 30, 32 are relatively long with respect to the lever arm above mentioned. In one preferred embodiment, the ratio of the length of one-half of the base to the lever arm, that is, the distance from the ground to the mounting plates 46, 48, is 5:1. The greater this ratio, the more the component of a horizontal wind force tending to tip the structure is reduced.

## 3. Force Applied

Mounting of the bottom of the frame directly to the base by means of the springs results in the entire force applied to the frame acting to deflect the frame structure downwardly. This is opposed to a display device of this general type wherein the frame structure is pivotally mounted intermediate its upper and lower ends. In such a construction, the portion of the wind force above the pivot point tends to tilt the device in one direction while the force below the pivot point tends to pivot

the device in the other direction. Assuming that the pivot point is closer to the top than it is to the bottom, there will be a resultant force tending to rotate the sign. However, this is less than the main wind force and additionally there is always a force tending to tip the entire structure over.

4. Twin Supports

The use of a pair of springs 16, 18 as opposed to the use of a single spring to support the frame structure prevents canting or twisting of the sign around a vertical axis. The frame structure is constrained to deflect in the manner illustrated in FIG. 2 rather than twisting which may cause damage to the spring structure and may result in tipping of the device.

5. Free-Standing Device

The poster display device 10 stands freely on the ground support surface as opposed to being anchored in some fashion in the ground. This results in an economical device because there is no installation expense. Even though the device is free-standing, it will not tip as has previously been discussed.

The springs 16, 18 are wound with the coils thereof in compression, that is, the coils press against one another. An optimum intercoil pressure is chosen for each different sized display device. The springs are wound with the maximum possible intercoil pressure because this permits reduction in the diameter of the spring wire and thus reduces the cost of the spring. However, the coils cannot be overly tight else the spring will not deflect at the proper pressure (which is just below that which would cause tipping of the device). Additional advantages of this spring construction are that it holds the poster frame erect under mild wind pressures thus avoiding constant swinging motion of the top portion of the frame, and the spring, for a given wire type and size, is stronger thus raising the frame faster from the down position after the wind force diminishes.

FIGS. 4, 5 and 6 illustrate an alternate embodiment of the invention. The poster display device 62 is in many respects similar to the poster display device 10. The base structure 64 and frame structure 66 are substantially identical to those previously described. However, the spring structure has been modified.

A torsion spring 68 extends between and interconnects the spaced-apart tubular base members 70, 72. The torsion spring 68 has a square cross section as shown in FIG. 5. The ends of the torsion spring are cylindrical as illustrated in FIG. 6. A bracket 76, 78 is provided on each of the tubular members 70, 72 to receive the ends of the torsion spring. Each bracket has a setscrew 80, 82 to engage the ends of the spring. The setscrews permit angular adjustment of the spring 68 to the end that the frame structure 66 may be oriented in a vertical plane.

A pair of brackets 84, 86 extend from the underside of the frame structure 66. The brackets 84, 86 have square openings to receive the torsion spring. A setscrew 88 is provided to engage the torsion spring and prevent longitudinal movement of the frame structure therealong. As will be appreciated, the spring 68 will yield under a turning force and twist about the anchored ends thereof to permit deflection of the frame structure in the manner illustrated in FIG. 2.

What I claim as my invention is:

1. A display device comprising an unanchored base, said

base including a pair of spaced-apart elongated ground-engaging means, an upstanding frame structure having a relatively large surface area for receiving display indicia, a spring structure mounting the frame structure onto the base, said spring structure comprising an elongated torsion spring extending entirely across the base, a pair of spaced-apart brackets securing the frame structure to the torsion spring, said spring structure being mounted centrally of the ground-engaging means with the plane of the frame structure at substantially right angles to the longitudinal axis of said ground-engaging means, the surface area of the frame being of a size which normally causes displacement of the base upon application of a sufficient wind force thereagainst, said spring structure normally maintaining the frame structure in an upright position and being yieldable in either direction along an axis generally parallel to the plane of the frame structure to permit downward deflection thereof, the area of the frame structure being proportioned to the size of the base to result in downward deflection of the frame structure upon a force applied thereto without displacement of the base.

2. The display device defined in claim 1 and further characterized in that the ends of said torsion springs are generally cylindrical, a pair of brackets on the base each rotatably receiving one cylindrical end of the torsion spring, and fastening means for engagement with the ends of the torsion spring to secure the torsion spring against rotation, said fastening means being releasable to permit angular adjustment of the torsion spring.

3. A display device comprising an unanchored base, said base comprising a pair of spaced-apart generally parallel elongated ground-engaging members, a pair of spaced-apart coil springs extending upwardly from the base, an upstanding frame structure secured to and supported solely by the upper ends of the springs, said frame structure having a relatively large surface area for receiving display indicia, the surface area of the frame being of a size which would normally cause displacement of the base upon application of a sufficient wind force thereagainst, said springs being yieldable in a direction to permit downward deflection of the frame structure, the coils of said springs being in compression with respect to each other, the amount of compression being such that the springs will deflect upon application of a force thereto less than that necessary to tip the device, the area of the frame structure being proportioned to the size of the base to result in downward deflection of the frame structure upon a force being applied thereto without displacement of the base.

4. The display device in accordance with claim 3 and further characterized in that the central portion of each ground-engaging member is raised a short distance above the ground level to provide a minimal lever action tending to tip the display device upon application of a force to the frame structure, said coil springs being positioned on said central portions.

5. The device in accordance with claim 4 and further characterized in that the ratio of the distance of said central portions of the ground-engaging members above ground level to one-half the length of the ground-engaging members is approximately 1:5.

\* \* \* \* \*

60

65

70

75